



Business Mail Rate card

**Royal Mail Business Mail[®]
and Business Mail 1st Class**

January 2018

Helping your business thrive and prosper

In a digital world, consumers place a high value on mail. We believe in the power of 1 to 1 communications to build customer relationships. Technology has transformed communications, but the core strengths of mail have endured and in some cases grown even stronger. Mail helps you connect with your customers and attract new customers in a way that few other channels can, especially when combined with digital.

Royal Mail is the UK's designated Universal Postal Service Provider, supporting customers, businesses and communities across the country. We are the only company that has the capability to deliver a 'one-price-goes-anywhere', six-days-a-week service on a range of letters and parcels to more than 29 million addresses across the UK.

Online Price Calculator

Use our online price calculator to find the best options for your mailing. There's also a downloadable excel version.

royalmailtechnical.com/calculator

For prices that are changing in January 2018 please visit: royalmail.com/prices2018. For all other prices visit royalmail.com/current-postage-prices

From 2 January 2018 prices in this rate card can be found at royalmail.com/business-mail

Although correct at the time this price guide was produced (December 2017), postal prices, fees and other conditions are subject to revision from time to time and services may need to be added or withdrawn.

Up-to-date information may be obtained by visiting royalmail.com

Contents

Know your formats	4
<hr/>	
Business Mail 1st Class & Business Mail	
<hr/>	
Unsorted: Full prices and per gram increments	5
Low Sort: Full prices and per gram increments	8
Calculating the price of your mailing	10
High Sort: Full prices and per gram increments	11
Calculating the price of your mailing	13
<hr/>	
Adjustment charges	14
<hr/>	

Know your formats

Here are the formats we use to work out the postage. Each format has its own size and weight limits. The illustrations below will help you work out which format your item will fall into.

Letter Up to 100g

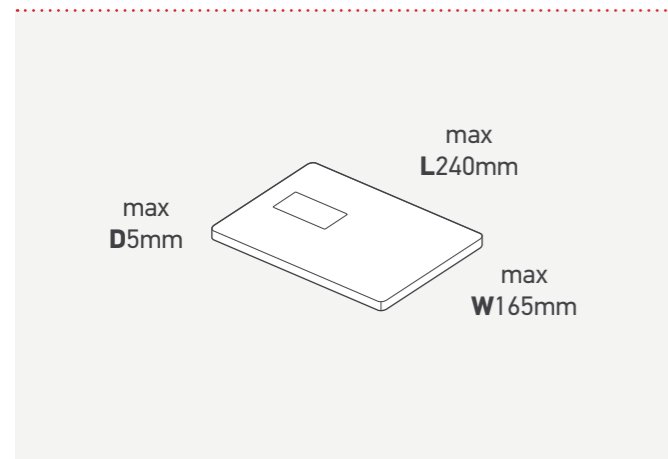

Large Letter Up to 750g

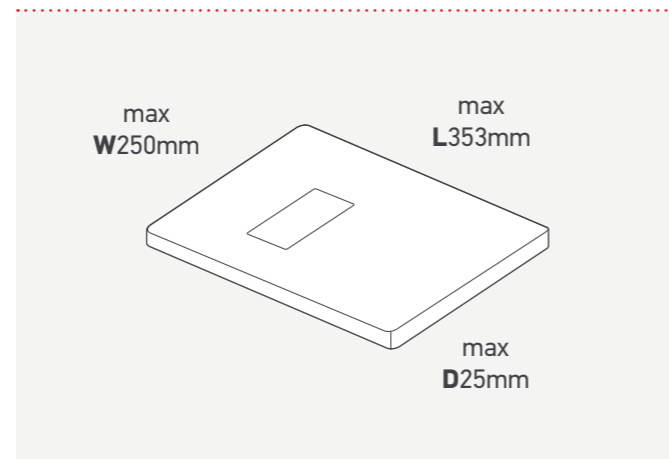

Large Letter – machine readable Up to 750g

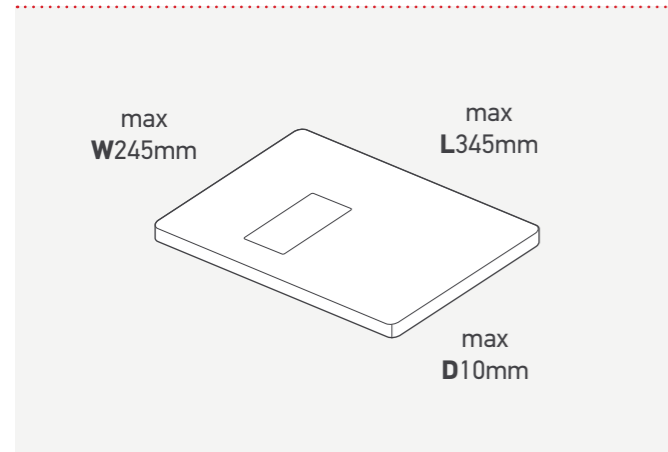

There is no Parcel option in Business Mail and goods are not permitted in Business Mail Large Letters. For information on Parcels services please visit royalmail.com/parcels

Business Mail

Unsorted

Table 1 – Letter: Standard unsorted options

Delivery Speed	Option	Product Code	Weight up to and including	Number of items per sales order [†]				
				1-999	1,000-2,499	2,500-9,999	10,000-24,999	25,000+
1st Class	Standard	STL	100g	58.0p	56.1p	54.9p	53.7p	52.5p
	Account ^{††}	UNA	100g	56.0p	54.2p	53.0p	51.9p	50.7p
2nd Class	Standard	STL	100g	40.0p	39.1p	38.2p	37.3p	36.5p
	Account ^{††}	UNB	100g	38.0p	37.1p	36.3p	35.4p	34.7p

Prices in this table exclude VAT, which is charged at the standard rate.

[†]In order to qualify for a price based on number of items, items must be of the same service, class and format, and be contained on a single sales order.

^{††}Barcode savings. A barcode is required for the Account options. For further information visit royalmail.com/barcodesavings

Unsorted

Table 2 – Letter: Machine-readable unsorted options

Delivery Speed	Product Code	Option	Weight up to and including	Number of items per sales order [†]						
				1-249	250-499	500-999	1,000-2,499	2,500-9,999	10,000-24,999	25,000+
1st Class	UNI	Advanced	100g	56.0p	47.8p	47.8p	47.0p	46.0p	45.1p	44.0p
	EBR	Mailmark	100g	n/a	n/a	46.6p	45.8p	44.8p	43.8p	42.9p
	CL3	OCR	100g	n/a	n/a	48.5p	47.7p	46.6p	45.6p	44.6p
2nd Class	UNJ	Advanced	100g	38.0p	31.2p	31.2p	30.6p	30.0p	29.4p	28.7p
	EBS	Mailmark	100g	n/a	n/a	30.1p	29.6p	28.9p	28.3p	27.7p
	CL4	OCR	100g	n/a	n/a	31.2p	30.7p	30.0p	29.4p	28.7p

Prices in this table exclude VAT, which is charged at the standard rate.

[†]In order to qualify for a price based on number of items, items must be of the same service, class and format, and be contained on a single sales order.

Mailings of less than the minimum volumes may be refused or charged at a higher price.

For Business Mail Advanced (BMA) posted via Mailmark Franking machines:

(New process for mail pieces without a 12 alpha character licence that do not require an OBA Sales Order)

Prices franked per item: Business Mail Advanced 1st Class 58p
Business Mail Advanced 2nd Class 38p

All credit or debit will be automatically applied to your account with your franking machine supplier. You will receive a VAT statement and Franking Account statement monthly.

For Business Mail Advanced (BMA) posted via Smartmeter and Mailmark Franking machines:

(For mail pieces with a 12 alpha character licence that require use of an OBA Sales Order)

Prices franked per item: Business Mail Advanced 1st Class 72p
Business Mail Advanced 2nd Class 54p

These higher control prices are before the BMA discount has been awarded. Discounted BMA prices are shown in the Business Mail rate card.

All BMA franking customers

BMA items which do not qualify will be charged at 57p (exc VAT) for 1st Class, and 39p (exc VAT) for 2nd Class. Note all BMA prices are subject to VAT.

For users of Mailmark franking technology, the most up to date and best value franking tariff is always in your mailmark machine.

Business Mail

Unsorted

Table 3 – Large Letter: Standard unsorted options

Delivery Speed	Option	Product Code	Weight up to and including	Number of items per sales order [†]				
				1-249	250-749	750-1,999	2,000-4,999	5,000+
1st Class	Standard	STL	100g	90.0p	88.6p	87.2p	85.4p	83.5p
			250g	125.0p	123.1p	121.1p	118.6p	116.0p
			500g	161.0p	158.5p	156.0p	152.7p	149.4p
			750g	227.0p	223.5p	220.0p	215.3p	210.7p
	Account ^{††}	UNA	100g	88.0p	86.6p	85.3p	83.5p	81.7p
			250g	123.0p	121.1p	119.2p	116.7p	114.1p
			500g	159.0p	156.5p	154.1p	150.8p	147.6p
			750g	225.0p	221.5p	218.0p	213.4p	208.8p
2nd Class	Standard	STL	100g	70.0p	68.8p	67.4p	65.8p	64.4p
			250g	98.0p	96.4p	94.4p	92.2p	90.1p
			500g	126.0p	123.9p	121.3p	118.5p	115.9p
			750g	178.0p	175.1p	171.4p	167.4p	163.7p
	Account ^{††}	UNB	100g	68.0p	66.9p	65.5p	64.0p	62.5p
			250g	96.0p	94.4p	92.4p	90.3p	88.3p
			500g	124.0p	122.0p	119.4p	116.6p	114.0p
			750g	176.0p	173.1p	169.5p	165.5p	161.8p

Prices in this table exclude VAT, which is charged at the standard rate.

[†]In order to qualify for a price based on number of items, items must be of the same service, class and format, and be contained on a single sales order.

^{††}Barcode savings. A barcode is required for the Account options. For further information visit royalmail.com/barcodesavings

Business Mail

Unsorted

Table 4 – Large Letter: Machine-readable unsorted options

Delivery Speed	Option	Product Code	Weight up to and including	Number of items per sales order				
				1-249	250-749	750-1,999	2,000-4,999	5,000+
1st Class	Mailmark	EBR	100g	n/a	78.1p	76.4p	74.8p	73.1p
			250g	n/a	111.6p	109.2p	106.9p	104.5p
			500g	n/a	148.2p	144.9p	141.9p	138.7p
			750g	n/a	210.5p	205.8p	201.6p	197.1p
	Advanced	UNI	100g	88.0p	80.6p	78.8p	77.2p	75.4p
			250g	123.0p	112.7p	110.1p	107.9p	105.4p
			500g	159.0p	145.6p	142.3p	139.4p	136.3p
			750g	225.0p	206.1p	201.4p	197.3p	192.8p
	OCR	CL3	100g	n/a	80.6p	78.8p	77.2p	75.4p
			250g	n/a	115.1p	112.6p	110.3p	107.8p
			500g	n/a	152.7p	149.3p	146.2p	143.0p
			750g	n/a	216.9p	212.2p	207.8p	203.1p
2nd Class	Mailmark	EBS	100g	n/a	61.9p	60.5p	59.3p	58.0p
			250g	n/a	89.8p	87.8p	86.0p	84.1p
			500g	n/a	119.8p	117.1p	114.7p	112.1p
			750g	n/a	171.1p	167.3p	163.8p	160.2p
	Advanced	UNJ	100g	68.0p	64.3p	62.9p	61.5p	60.5p
			250g	96.0p	90.7p	88.8p	86.9p	85.4p
			500g	124.0p	117.2p	114.7p	112.2p	110.4p
			750g	176.0p	166.3p	162.8p	159.3p	156.6p
	OCR	CL4	100g	n/a	63.9p	62.5p	61.2p	59.8p
			250g	n/a	92.6p	90.5p	88.6p	86.7p
			500g	n/a	123.4p	120.7p	118.2p	115.6p
			750g	n/a	176.3p	172.4p	168.8p	165.0p

Prices in this table exclude VAT, which is charged at the standard rate.

[†]In order to qualify for a price based on number of items, items must be of the same service, class and format, and be contained on a single sales order.

Mailings of less than the minimum volume may be refused or charged at a higher price.

Business Mail

Low Sort

Table 1 – Full prices and per gram increments

Format	Weight	1st Class		2nd Class		Economy	
		Full Price	Per Gram Increment	Full Price	Per Gram Increment	Full Price	Per Gram Increment
Letter	0-100g	54.8p	n/a	38.0p	n/a	34.4p	n/a
Large Letter OCR	0-100g	69.9p	n/a	49.4p	n/a	44.1p	n/a
	101-250g	78.9p	n/a	64.3p	n/a	57.0p	n/a
	251-750g	78.9p	0.2233p	64.3p	0.1644p	57.0p	0.1634p
Large Letter Mailmark	0-100g	68.4p	n/a	48.7p	n/a	43.5p	n/a
	101-250g	76.9p	n/a	63.1p	n/a	56.0p	n/a
	251-750g	76.9p	0.2083p	63.1p	0.1594p	56.0p	0.1557p

Prices in this table exclude VAT, which is charged at the standard rate.

Low Sort

Table 2 – Sortation and machine-readable discount

	1st Class		2nd Class		Economy	
	Direct Items	Product Code	Direct Items	Product Code	Direct Items	Product Code
Letters OCR	19.90%	MXD	19.90%	MXE	19.90%	MXF
Letters Mailmark	22.80%	EBA	22.80%	EBB	22.90%	EBC
Large Letters OCR	10.25%	MXD	10.35%	MXE	10.45%	MXF
Large Letters Mailmark	12.45%	EBA	12.55%	EBB	12.65%	EBC

Business Mail

Low Sort

Table 3 – Volume Related Discount***

Format	Number of Direct Items	1st Class	2nd Class	Economy
		Direct Items	Direct Items	Direct Items
Letter	4,000 – 19,999	0.00%	0.00%	0.00%
	20,000 – 39,999	1.50%	1.50%	1.50%
	40,000 – 79,999	3.50%	3.50%	3.50%
	80,000 – 119,999	4.50%	4.50%	4.50%
	120,000 +	5.30%	5.30%	5.30%
Large Letter OCR	1,000 – 9,999	0.00%	0.00%	0.00%
	10,000 – 19,999	1.00%	1.00%	1.00%
	20,000 – 39,999	1.50%	1.50%	1.50%
	40,000 – 59,999	2.00%	2.00%	2.00%
	60,000 +	3.00%	3.00%	3.00%
Large Letter Mailmark barcode	1,000 – 9,999	0.00%	0.00%	0.00%
	10,000 – 19,999	1.50%	1.50%	1.50%
	20,000 – 39,999	3.50%	3.50%	3.50%
	40,000 – 59,999	4.50%	4.50%	4.50%
	60,000 +	5.30%	5.30%	5.20%

***Volume Related Discounts for Direct items are based on total daily volumes over multiple sales order lines providing all items are posted on the same day; posted from the same posting location (site); posted via the same product and format, and only apply to Direct items (Residue items are not counted towards the calculation).

Mailing of less than 4,000 Letters or 1,000 Large Letters may be charged at a higher rate.

Low Sort

Table 4 – Trayed Mail Savings

	Saving per item
Low Sort Letters	0.27p
Low Sort Large Letters (up to 10mm thick)	0.70p
Tray savings apply after all other discounts (VRDs, sortation etc) are applied but before VAT	

Business Mail

Calculating the price of your mailing

Step 1: Find the full price for the items you are mailing from Table 1. If the item is Large Letter format and weighs more than 250g, then an incremental price should be added to the full price based on the exact weight of the item. The incremental price is calculated as the incremental weight in grams above 250g multiplied by the gram price increment. The result is rounded to the nearest 1/10th of a penny.

Step 2: Identify the appropriate sortation and machine-readable discount from Table 2.

Step 3: Add to the sortation and machine-readable discount the applicable volume related discount from Table 3.

Step 4: Apply the aggregate discount percentage to the full price to calculate the item price.

Step 5: Multiply the item price by the number of items to calculate the total transaction price excluding VAT.

Worked example

A Low Sort Economy posting of 102,000 Letters Mailmark weighing 80g each.

Step 1: The full price for a Low Sort Economy Mailmark option 80g Letter = 34.4p from Table 1.

Step 2: Sortation and machine-readable discount for Low Sort Letters Mailmark = 22.90% from Table 2.

Step 3: VRD from Table 3 = 4.50%, added to the sortation and machine-readable discount of 22.90% gives total aggregate discount of 27.40%.

Step 4: Price per item = $34.4p \times (100\% - 27.40\%) = 24.9744p$.

Step 5: Total price of mailing = $(24.9744p \times 102,000) / 100 = \text{£}25,473.89$ (excluding VAT).

Trayed Mail Savings:

Letter mailings presented in trays will save 0.27p per item from Table 4 = $(0.27p \times 102,000) / 100 = \text{£}275.40$ (excluding VAT).

Total tray price of mailing = $\text{£}25,473.89 - \text{£}275.40 = \text{£}25,198.49$ (excluding VAT).

Business Mail

High Sort

Table 1 – Full prices and per gram increments

Format	Weight	1st Class		2nd Class		Economy**	
		Full Price	Per Gram Increment	Full Price	Per Gram Increment	Full Price	Per Gram Increment
Product Code		LE1		LE2		LE3	
Letter	0-100g	57.3p	n/a	39.4p	n/a	33.0p	n/a
Large Letter	0-100g	70.5p	n/a	50.1p	n/a	44.6p	n/a
	101-250g	79.3p	n/a	65.0p	n/a	57.3p	n/a
	251-750g	79.3p	0.2146p	65.0p	0.1640p	57.3p	0.1587p

Prices in this table exclude VAT, which is charged at the standard rate.

High Sort

Table 2 – Sortation Discounts

Format	1st Class		2nd Class		Economy**	
	Direct Items	Residue Items	Direct Items	Residue Items	Direct Items	Residue Items
Letter	8.55%	6.05%	8.75%	6.25%	8.90%	6.40%
Large Letter	12.55%	2.55%	12.75%	2.85%	12.75%	2.75%

High Sort

Table 3 – Volume Related Discounts for Direct***

Format	Number of Direct Items	1st Class	2nd Class	Economy**
		Direct Items	Direct Items	Direct Items
Letter	4,000 – 19,999	0.00%	0.00%	0.00%
	20,000 – 39,999	1.50%	1.50%	1.50%
	40,000 – 79,999	3.50%	3.50%	3.50%
	80,000 – 119,999	4.50%	4.50%	4.50%
	120,000 +	5.30%	5.30%	5.30%
Large Letter	1,000 – 9,999	0.00%	0.00%	0.00%
	10,000 – 19,999	1.50%	1.50%	1.50%
	20,000 – 39,999	3.50%	3.50%	3.50%
	40,000 – 59,999	4.50%	4.50%	4.50%
	60,000 +	5.30%	5.30%	5.30%

***Volume Related Discounts for Direct items are based on total daily volumes over multiple sales order lines providing all items are posted on the same day; posted from the same posting location (site); posted via the same product and format, and only apply to Direct items (Residue items are not counted towards the calculation).

Mailing of less than 4,000 Letters or 1,000 Large Letters may be charged at a higher rate.

Business Mail

Aggregating volumes on Direct selections to achieve and maximise Volume Related Discounts: In order to reach the VRD threshold on any given posting day, and to maximise the level of VRD obtainable, you can aggregate volumes on Direct selections in 2 ways:

1. You can combine a number of the same product / service level mailings onto one confirmed sales order. You will need to show in the comments field all the job reference numbers or part jobs included on that confirmed sales order. If you do this and then have multiple entries on a single confirmed sales order you must link the individual lines with the appropriate Customer Reference Number (CRN) to maximise your Volume Related Discount.
2. If you are unable to show all mailings for one day on a single confirmed sales order (usually because mailings are at different times) you must put the same Customer Reference Number (CRN) on each confirmed sales order and against each multiple entry. It is not possible to aggregate different sales orders posted on the same day for any unsorted products (Business Mail, Advertising Mail and Business Mail Advanced option).

Any applicable VRDs are calculated at the time you confirm your sales order and will be reflected on the invoice for that date of posting.

High Sort

Table 4 – Volume Related Discounts for Residue***

Format	Number of Direct Items	1st Class	2nd Class	Economy**
		Residue Items	Residue Items	Residue Items
Letter	4,000 – 19,999	0.00%	0.00%	0.00%
	20,000 – 39,999	1.50%	1.50%	1.00%
	40,000 – 79,999	2.50%	2.50%	1.50%
	80,000 – 119,999	2.50%	2.50%	2.00%
	120,000 +	3.00%	3.00%	2.00%
Large Letter	1,000 – 9,999	0.00%	0.00%	0.00%
	10,000 – 19,999	1.50%	1.50%	1.00%
	20,000 – 39,999	2.50%	2.50%	1.50%
	40,000 – 59,999	2.50%	2.50%	2.00%
	60,000 +	3.00%	3.00%	2.00%

***Direct selection volumes or multiple posting volumes against any other sales order lines cannot be counted towards the Volume Related Discount calculation for Residue items

High Sort

Table 5 – Trayed Mail Savings

	Saving per item
High Sort Letters	0.27p
High Sort Large Letters (up to 10mm thick)	0.70p
Tray savings apply after all other discounts (VRDs, sortation etc) are applied but before VAT	

Business Mail

Calculating the price of your mailing

Step 1: Find the full price for the items you are mailing from Table 1. If the item weighs more than 250g, then an incremental price should be added to the full price based on the exact weight of the item. The incremental price is calculated as the incremental weight in grams above 250g multiplied by the gram price increment. The result is rounded to the nearest 1/10th of a penny.

Step 2: Identify the appropriate sortation discount from Table 2.

Step 3: Add to the sortation discount the applicable volume related discount for Direct (from Table 3) and Residue items (from Table 4).

Step 4: Apply the aggregate discount to the full price to calculate the item prices for Direct and Residue items.

Step 5: Multiply the Direct and Residue prices by the number of items in each category.

Step 6: Add the Direct and Residue values together to calculate the total transaction price excluding VAT.

Worked example

A High Sort 2nd Class posting of 102,000 Large Letters weighing 302g each. 90,000 of these are Directs and 12,000 are Residues.

Step 1: The full price = 65.00p + ((302 – 250) x 0.1640p) = 73.5280p, rounded to the nearest 1/10th of a penny = 73.5p.

Step 2: Direct discount = 12.75%, Residue discount = 2.85% from Table 2.

Step 3: Direct VRD from Table 3 = 5.3%, added to the Direct discount of 12.75% gives a total discount for Direct items of 18.05%. Residue VRD from Table 4 = 1.5%, added to the Residue discount of 2.85% gives a total discount for Residue items of 4.35%.

Step 4: Price of Directs = 73.5p x (100% - 18.05%) = 60.2333p
Price of Residues = 73.5p x (100% - 4.35%) = 70.3028p

Step 5: Price of Directs in mailing = (60.2333p x 90,000)/100 = £54,209.93
Price of Residues in mailing = (70.3028p x 12,000)/100 = £8,436.33

Step 6: Total for this mailing = £54,209.93 + £8,436.33 = £62,646.26 (excluding VAT).

Trayed Mail Savings:

Large Letter mailings presented in trays will save 0.7p per item from Table 5 = (0.7p x 102,000)/100 = £714.00 (excluding VAT).

Total tray price of mailing = £62,646.26 - £714.00 = £61,932.26 (excluding VAT).

Adjustment Charges

Mailmark Adjustment Charges

Fault	Applies to	Flat Fee	Per Item Fee	Note
Missorts	Mailmark Letters	n/a	14.95p	
Missorts	Mailmark Large Letters	n/a	39.75p	
International item as domestic	Mailmark Letters and Large Letters	n/a	£1.47	Adjustment charges only apply when one or a combination of charges result in a charge of £10 or more per eManifest
Non machine processed	Mailmark Letters	n/a	1.98p*	
Non machine processed	Mailmark Large Letters	n/a	3.53p*	
Postcode accuracy	Mailmark Letters	n/a	7.81p	
Postcode accuracy	Mailmark Large Letters	n/a	15.30p	Postcode and Delivery point suffix accuracy adjustment charges only apply if the combined result drops below 90% per eManifest
Delivery point suffix accuracy	Mailmark Letters and Large Letters	n/a	0.84p	
Missing or incorrect eManifest ID	Mailmark Letters and Large Letters	£26.39	n/a	per eManifest
Unmanifested volume and Duplicates	Mailmark Letters and Large Letters	£26.39	0.45pLs/0.71pLLs	per supply chain
Incorrect SCID	Mailmark Letters and Large Letters	£26.39	n/a	per eManifest
Item ID mismatch	Mailmark Letters and Large Letters	£26.39	n/a	per eManifest

Account and Advanced Charges

Fault	Applies to	Class	Format	Flat Fee	Per Item Fee
Barcode not seen	Unsorted Account	1st Class and 2nd Class	Letters and Large Letters	n/a	2p
Sales Order Under Declared – UK	Account and Advanced	1st Class	Letters	n/a	56p
		2nd Class	Letters		38p
		1st Class	Large Letters		£1.23
		2nd Class	Large Letters		96p
Sales Order Under Declared – International	Account and Advanced		Letters and Large Letters	n/a	£1.47L/£3.60LL
Not highly machinable	Advanced	1st Class	Letters	n/a	8.2p
		2nd Class	Letters		6.8p
		1st Class	Large Letters		8.4p
		2nd Class	Large Letters		5.2p
Missing Sales Order	Account and Advanced			£26.39	n/a
Incorrect Sales Order	Account and Advanced			£26.39	n/a

Prices in these tables exclude VAT, which is charged at the standard rate.

Full details of the Mailmark adjustment framework are available at royalmail.com/mailmark

*The total amount charged for these faults will not exceed the price of the next available service.

**The difference in price between the volume declared versus the volume submitted.

Adjustment Charges

Machine Readable Adjustment Charges

Fault	Applies to	Flat Fee	Per item fee	Note
Low volume faults	Sorted	£26.39	n/a	per posting
Medium volume low impact faults	Sorted	£26.39	n/a	per posting
Medium volume high impact faults	Sorted	£26.39	adjustment	10% of posting adjusted
High volume low impact faults	Sorted and unsorted	£26.39*	n/a	per posting
High volume high impact faults	Sorted	£26.39	adjustment	100% of mailing adjusted
Incorrect licence design	BMA on account	£25.00	n/a	per month

Prices in this table exclude VAT, which is charged at the standard rate.

*Fee applies to sorted machine-readable mail only.

Full details of the Low/High machine readable faults are available in the Quick Guides at royalmailtechnical.com

Other Adjustment Charges

Fault	Applies to	Flat Fee	Per item fee	Note
Presentation errors	Sorted	£26.39	n/a	per posting
Incorrect labels/bag ties	Sorted	£26.39	20p	per label or tie
Incorrect cage cards	Sorted	£26.39	25p	per card used
Storage costs	Sorted	£26.39	25p	per cage per day
Overweight bags/bundles/trays	Sorted	£26.39	65p	per bag/tray generated
Overweight cages/Yorks	Sorted	£26.39	65p	per Cage/York generated
Minimum average per selection	Sorted	£26.39	adjustment	100% of mailing
Bulk surcharges	Unsorted	n/a	31p*	per item
Response and Advanced specification	Response	n/a	31p	per item
Response specification	Response	£25.00	n/a	per licence per month
No sales order or posting cheque	Sorted and unsorted	£26.39	n/a	per posting
Incorrect Sales Order	Sorted and unsorted	£26.39	n/a	per posting

Prices in this table exclude VAT, which is charged at the standard rate, except for Bulk surcharges.

*Bulk surcharges are exempt from VAT.

